

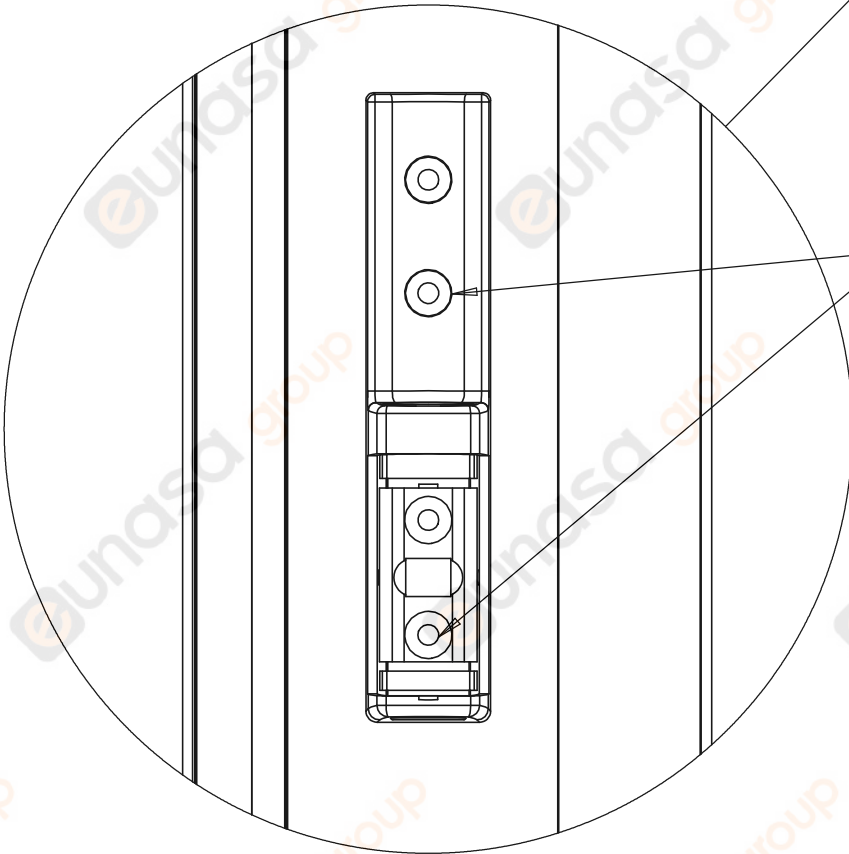

PH01



463



Retirar la bisagra PH01 del marco (ó panel) y colocar la bisagra G 463 haciendo coincidir estos dos agujeros con los ya existentes en el marco/panel. Hay que agujerear los otros dos agujeros.

DESCRIPCION / DESCRIPTION		PESO/WEIGHT (Kg) 5.84	MATERIAL/MATERIAL -	ACABADO/FINISH	
ESCALA/SCALE 1:20		PROYECTO/PROJECT SUSTITUIR BISAGRA PH01 por G 463		DIBUJADO / DRAWN AUSTIN	FECHA / DATE 23/01/2015
DIN A4				APROBADO / APPROVED	FECHA / DATE
kide Poligono Gardotza s/n 48710 Berriatua Bizkaia Tel. 0034946036200 Fax. 0034946036220 www.kide.com				Nº PLANO/DRAWING NUMB. MI-0006	REV./REV.